

DATA SHEET

PROFESIONAL GAS FRYER BURNER

FG70

Manual machine for high production or as a professional equipment. Due to its quality, it is a very durable and sturdy machine designed for industrial use.



TECHNICAL SPECIFICATIONS:

- **Suitable for outdoor use.**
- Body made of AISI304 18/10 stainless steel.
- Stainless steel tank integrated into the body.
- Wheels for easy mobility.
- High-power industrial burner with safety valve and permanent pilot light.
- High-precision digital thermostat [-1°C].
- Insulated with high-temperature SUPERWOLL thermal blanket, Density 128kg/m³, thickness 13mm. Except for chimneys.
- Exhaust chimneys made of AISI304 stainless steel, for hanging dosing equipment or potato cutters.
- Built according to CE regulations.
- Temperature range from 80°C to 200°C.
- 1" oil drain valve.
- Model: Express 621 burner.
- Fuel: butane/propane.

OPCIONAL:

- Special manufacturing for dimensions, tank depth, or conical/cylindrical shape.
- Lid.
- Mast for hanging dosing equipment or potato cutters.
- Insulation for chimneys.

MODELO: FG70

DIMENSIONS: LENGT 700mm. / WIDTH 700mm. / HIGH 800 mm.

POWER: 49 KW.

TOP DIAMETER: Ø600mm.

BOTTOM DIAMETER: Ø400mm.

INSIDE DIAMETERS: 170mm.

CAPACITY: 14 L.

VOLTAJE: N/A

DIMENSIONS

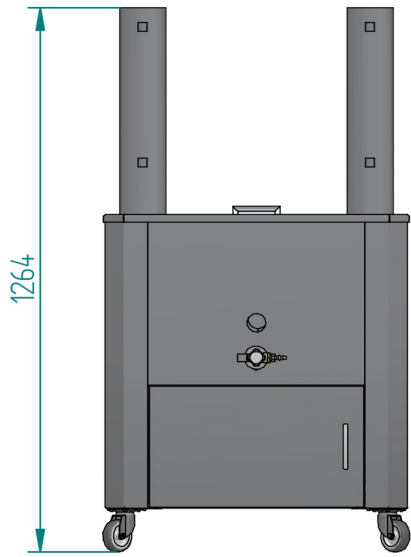

VISTA FRONTAL

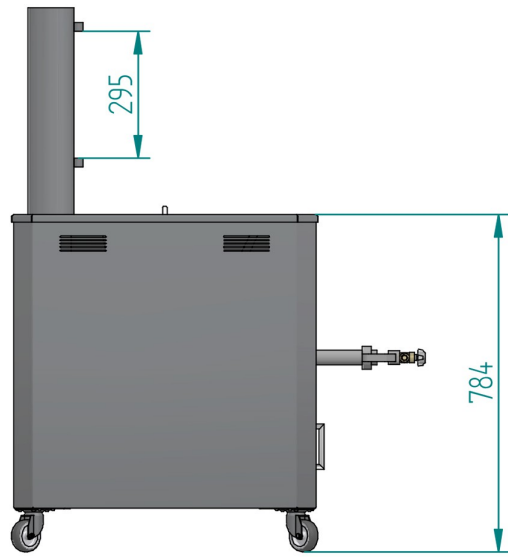

VISTA LATERAL

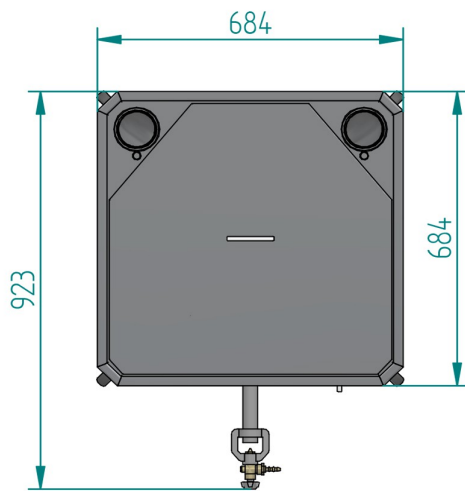

VISTA PLANTA

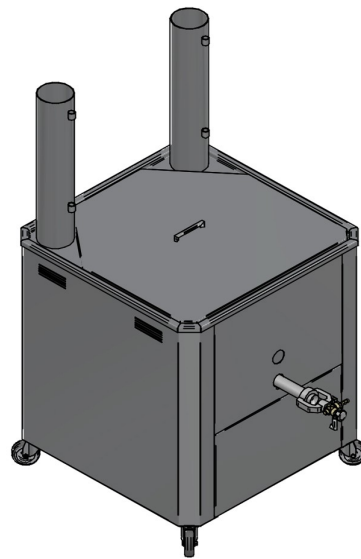

VISTA ISOMÉTRICA

**APROXIMATE WEIGHT: 42,5 Kg.
ELECTRICAL CONNECTION: N/A.**

The company reserves the right to make technical modifications without prior notice.

www.inhospaan.com

TYPE OF GAS: Butano/Propano.

V1.0 - 2021/06/14